



Shenzhen Hailingke Electronics Co., Ltd.

HLK-LD2410C

Human presence sensor module

manual

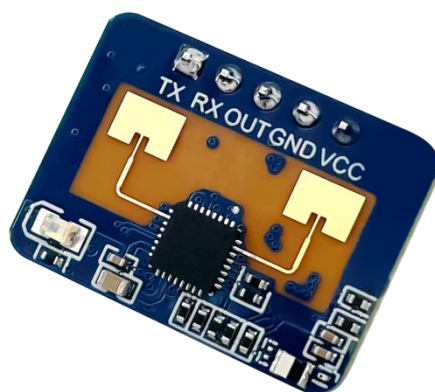

Version: V1.00

Modification date: 2022-11-7

Copyright@Shenzhen Hailingke Electronics Co., Ltd.

Table of contents

1 Product introduction.....	3
2 Product features and advantages.....	4
2.1 Features.....	4
2.2 Advantages of the solution.....	5
3 Application Scenarios.....	6
4 Hardware Description.....	7
4.1 Dimensions.....	7
4.2 Pin definition.....	8
5 Use and configuration.....	9
5.1 Typical Application Circuit.....	9
5.2 The role of configuration parameters.....	9
5.3 Description of Visual Configuration Tool.....	9
5.4 Installation method and sensing range.....	11
5.5 Installation conditions.....	13
6 Instructions for using Bluetooth.....	14
6.1 Installing the software.....	14
6.2 How to use.....	14
6.3 Bluetooth password.....	15
6.4 OTA upgrade.....	15
6.5 Bluetooth communication protocol.....	17
6.6 Turn on Bluetooth again.....	18
7 Performance and electrical parameters.....	18
8 Radome design guidelines.....	19
8.1 The effect of radome on the performance of mmWave sensor.....	19
8.2 Design principles of radome.....	19
8.3 Common materials.....	19
9 Revision History.....	20
10 Technical support and contact information.....	twenty one

1 product introduction

LD2410C is a high-sensitivity 24GHz human presence sensing module developed by Hilink Electronics. Its working principle is to use FMCW frequency modulation continuous wave to detect human targets in the set space, combined with radar signal processing and precise human body sensing algorithm, to realize high-sensitivity human body presence status sensing, which can identify human body in motion and static state, And it can calculate the auxiliary information such as the distance of the target.

This product is mainly used in indoor scenes, to detect whether there is movement or micro-movement of the human body in the area, and output the detection results in real time. The farthest sensing distance can reach 5 meters, and the distance resolution is 0.75m. Provides a visual configuration tool, which can easily configure the sensing distance range, sensing sensitivity in different intervals and unmanned delay time, etc., to adapt to different specific application requirements.

Support GPIO and UART output, plug and play, can be flexibly applied to different intelligent scenarios and terminal products.

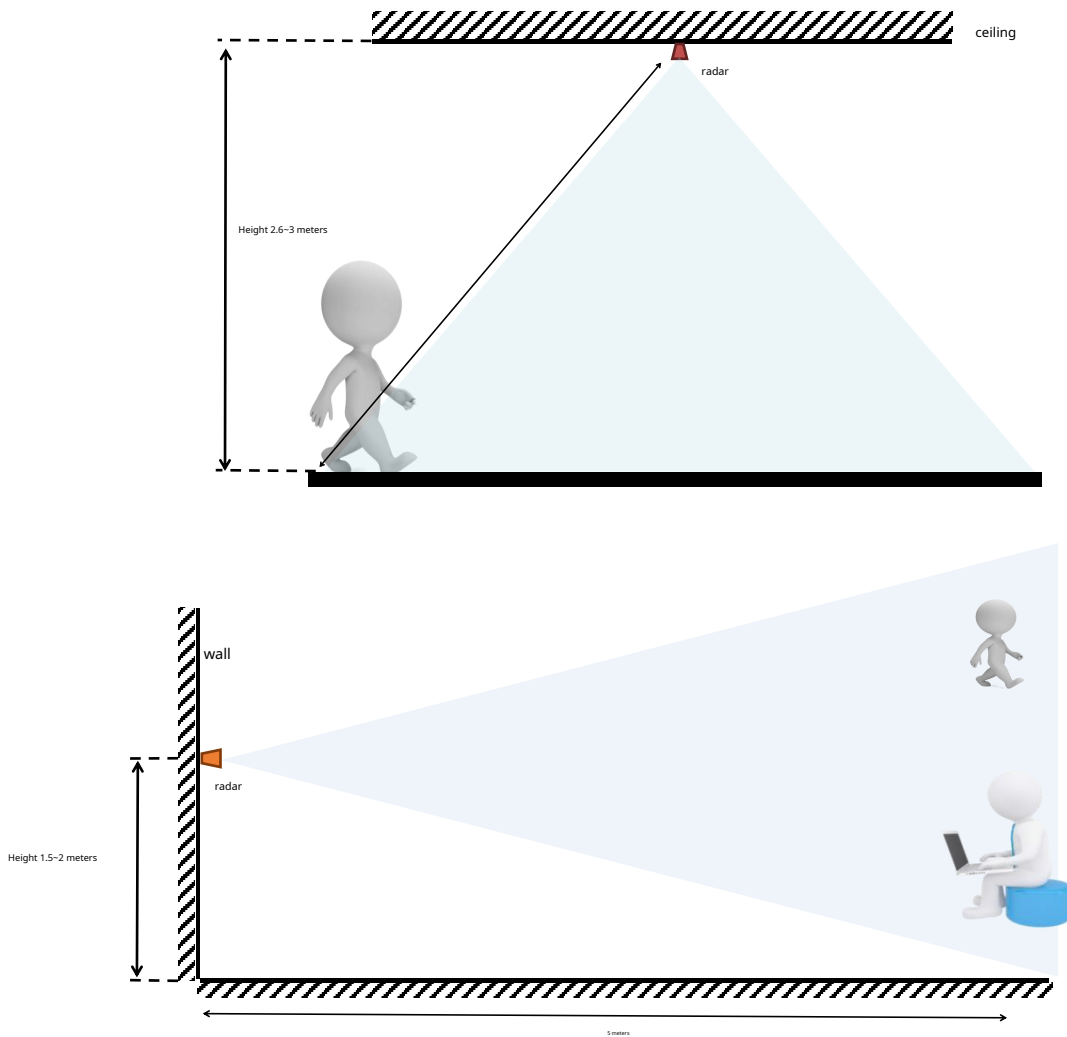

Figure 1 Diagram of usage

2 Product features and advantages

2.1 Features

- Plug and play, easy assembly

- The farthest sensing distance is up to 5 meters
- Large detection angle, coverage up to ± 60 degrees
- Accurate identification within the interval, support for sensing range division, shielding interference outside the interval
- Multi-level intelligent parameter adjustment can be realized through Bluetooth or serial port to meet the needs of scene changes
- Visual debugging and configuration tool
- Compact and simplified, the minimum size is only 16mmx22mm
- Support various installation methods such as ceiling hanging and wall hanging
- 24GHz ISM band, compliant with FCC and CE spectrum regulations
- The ultimate cost-effective choice

2.2 Solution Advantages

LD2410C human body sensing module adopts 24GHz millimeter-wave radar sensor technology. Compared with other solutions, it has obvious advantages in human body sensing applications:

1. In addition to being sensitive to moving human bodies, it can also sensitively detect static, micro-moving, sitting and lying human bodies that cannot be identified by traditional solutions;
2. It has good environmental adaptability, and the sensing effect is not affected by the surrounding environment such as temperature, brightness, humidity and light fluctuations;
3. It has good shell penetration and can work hidden inside the shell without opening holes on the product surface, which improves the product aesthetics;
4. The farthest sensing distance and the sensitivity of each distance door can be flexibly configured to achieve flexible and fine personalized configuration;
5. With Bluetooth function, you can directly use the APP to debug radar parameters without connecting to the serial port

	Infrared solution	visual scheme	ultrasound	lidar	millimeter wave radar
application flexibility	●	●	●	●	●
Resistance to environmental influences (weather light, etc.)	●	●	●	●	●
detection speed	●	●	●	●	●
Detection accuracy	●	●	●	●	●
resolution	●	●	●	●	●
directionality	●	●	●	●	●
Detection distance	●	●	●	●	●
Ability to penetrate materials	●	●	●	●	●
size	●	●	●	●	●
cost	●	●	●	●	●

● good ● generally ● weak

Figure 2 Comparison of the millimeter wave radar scheme with other schemes

3 Application Scenario

The LD2410C human body sensing module can detect and identify motion, micro-movement, and standing, sitting, and lying human bodies. It supports multi-level parameter adjustment and can be widely used in various AIoT scenarios. The commonly used types are as follows

- **Human sensor light control**

Perceive whether there are people in the space, and automatically control the lighting, such as lighting equipment in public places, various sensor lights, bulb lights, etc. **Human body induction wake-up**
- **of advertising screen and other equipment**

It is automatically turned on when people come, and automatically sleeps when no one is there to save power, and the information delivery
- is more accurate and efficient **life safety protection**

UV lamp work protection, preventing UV lamp from turning on when there are people around, causing personal injury, automatic detection and alarm in dangerous places, preventing people from entering specific high-risk spaces, such as high-risk places where coal mine blasting personnel enter high-risk places **Smart Appliances**
- If there is no one in the room for a long time, electrical appliances such as TV and air conditioner will be automatically turned off, which is energy-
- saving and safe **Smart security**

Detection and recognition of intrusion, stay, etc. in the designated area

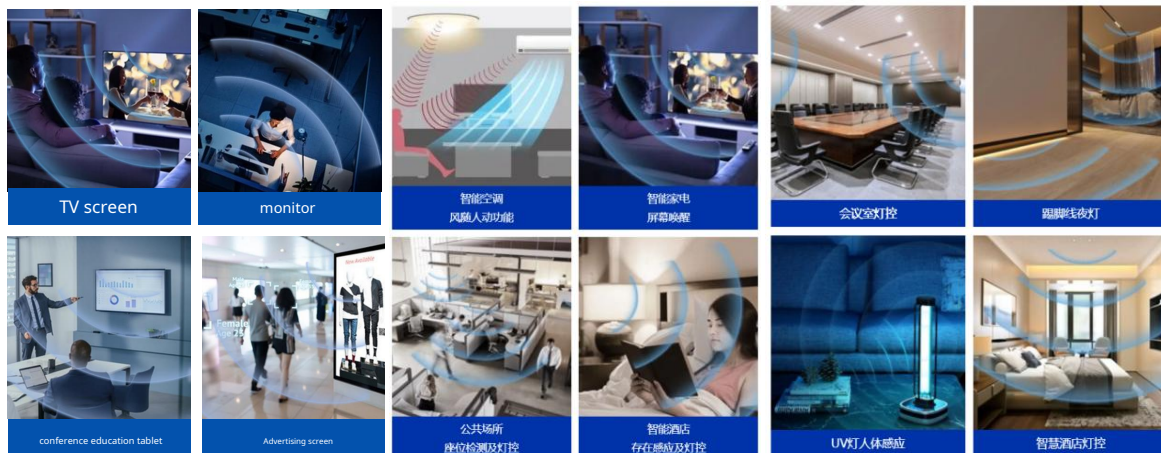

Figure 3 Application Scenarios

4 Hardware description

4.1 Dimensions

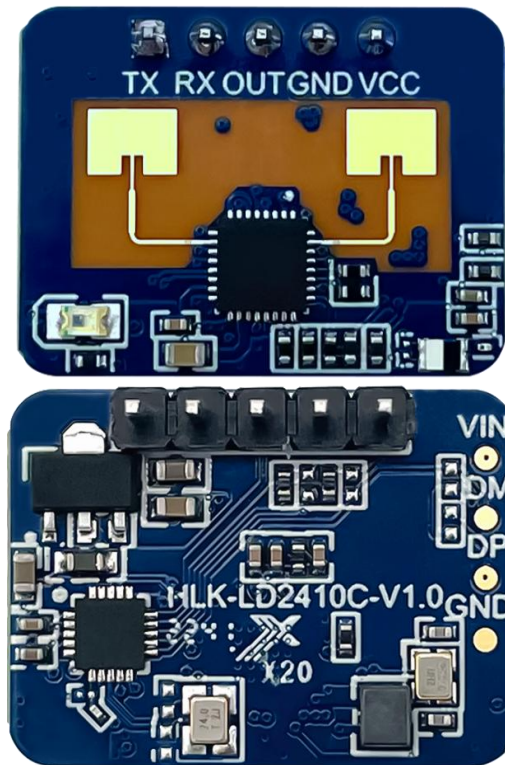

Figure 4 The physical picture of the module

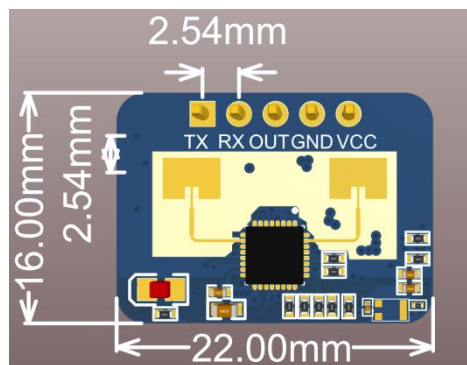

Figure 5 Module Dimensions

Module size: 16mmx22mm, 5 pin holes are reserved for the hardware (factory default with pins). The hole diameter of the pin hole is 0.9mm, and the pin spacing is 2.54mm.

4.2 Pin definition

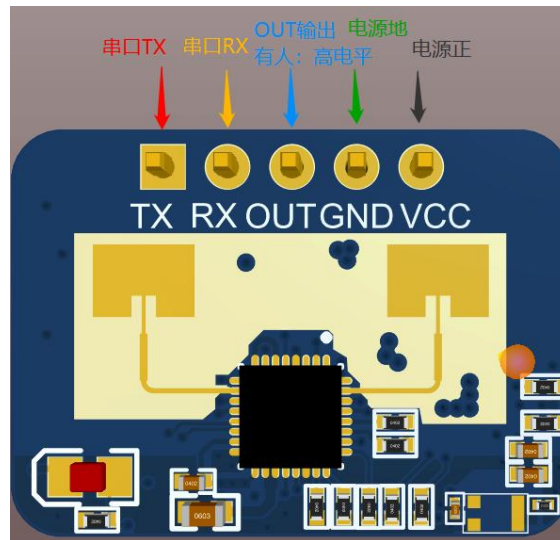

Figure 6 Module pin definition diagram

pin	symbol	name	Function
1	UART_Tx	Serial Tx	Serial port Tx pin
2	UART_Rx	Serial Rx	Serial port Rx pin
3	out	target state output	Human presence detected: output high level No human presence: output low level
4	GND	power ground	power ground
5	VCC	power input	Power supply input 5-12V (recommended 5V)

Table 1 Pin definition table

5 Use and configuration

5.1 Typical Application Circuit

The LD2410C module directly outputs the detected target state through an IO pin (high level for someone, low level for no one), and can also output the detection result data through the serial port according to the specified protocol. The serial port output data includes Target status and distance auxiliary information, etc., users can flexibly use according to specific application scenarios.

The power supply voltage of the module is 5V, and the power supply capacity of the input power supply is required to be greater than 200mA.

The module IO output level is 3.3V. The default serial port baud rate is 256000, 1 stop bit, no parity bit.

5.2 The role of configuration parameters

The user can modify the configuration parameters of the module through the serial port of LD2410C to meet different application requirements, and the configuration content will not be lost when the power is turned off. The configurable parameters include the following:

The furthest detection distance

Set the furthest detectable distance, only the human targets appearing within this furthest distance will be detected and the result will be output. Set it in units of distance gates, each distance gate is 0.75m.

Including the longest distance door for motion detection and the longest distance door for static detection, the range can be set from 1 to 8. For example, if the longest distance door is set to 2, only when there is a human body within 1.5m can it be effectively detected and the result output.

sensitivity

Only when the detected target energy value (range 0-100) is greater than the sensitivity value will it be determined that the target exists, otherwise it will be ignored.

The sensitivity value can be set from 0 to 100. Sensitivity can be set independently for each range gate, which can precisely adjust the detection in different distance ranges, local accurate detection or filter interference sources in specific areas.

In addition, if the sensitivity of a range gate is set to 100, the effect of not recognizing the target under this range gate can be achieved. For example, if the sensitivities of range gate 3 and range gate 4 are set to 20, and the sensitivities of other range gates are set to 100, then only the human body within the range of 2.25-3.75m from the module can be detected.

Duration of no one

When the radar outputs the results from someone to no one, it will report people for a period of time. If there is no one in the radar test range during this time period, the radar will report no one; if the radar detects people during this time period, it will be refreshed. This time, in seconds. It is equivalent to the unoccupied delay time. After the person leaves, the output state will be unoccupied only after keeping no one for more than this duration.

5.3 Description of Visual Configuration Tool

In order to facilitate users to quickly and efficiently test and configure the module, a PC-side PC configuration tool is provided. Users can use this tool software to connect to the serial port of the module, read and configure the parameters of the module, and also receive the detection results reported by the module. data, and real-time

The visual display greatly facilitates the user's use.

How to use the upper computer tools:

1. Correctly connect the module serial port with the USB to serial port tool;
2. Select the corresponding serial port number in the upper computer tool, set the baud rate to 256000, select the engineering mode, and click to connect the device;
3. After the connection is successful, click the start button, and the graphical interface on the right will display the test results and data;
4. After connecting, when the start button is not clicked, or click stop after starting, the mode parameter information can be read or set;

Note: After clicking start, the parameters cannot be read and configured, and the configuration can only be performed after stopping.

The interface and common functions of the upper computer tool are as follows:

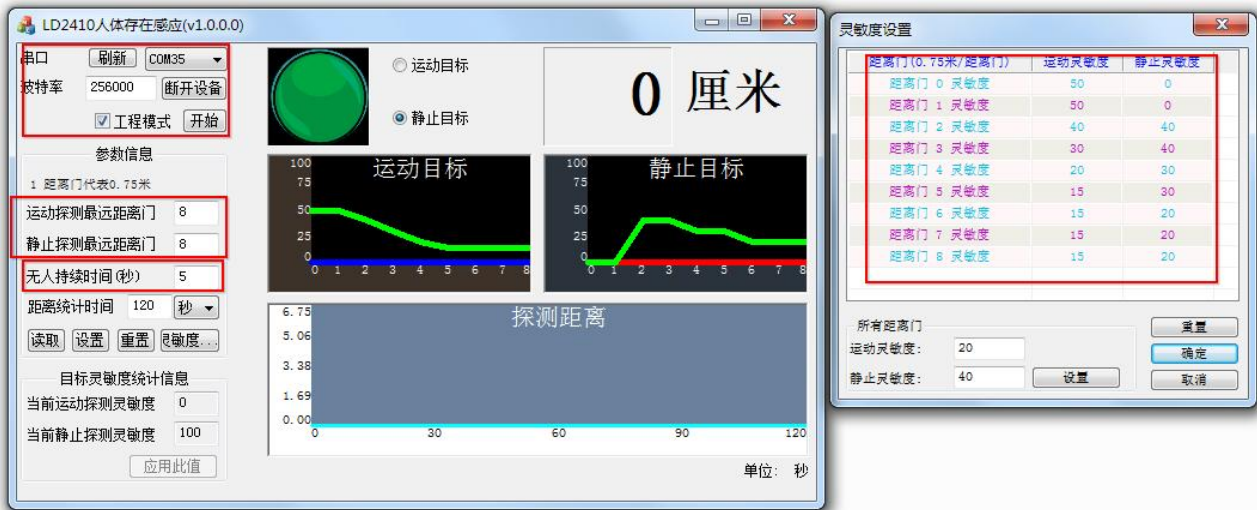

The ball is the output indicator of the target state: red represents a man-made moving target, and purple represents a man-made stationary target;

Green means no one

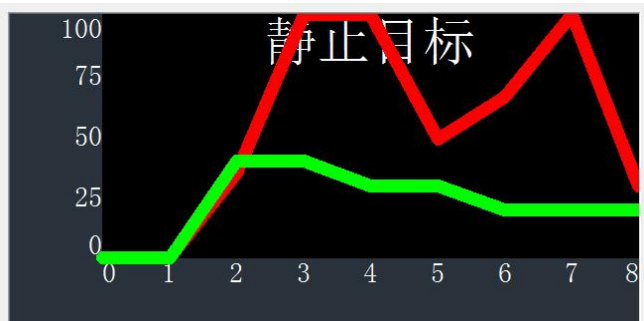
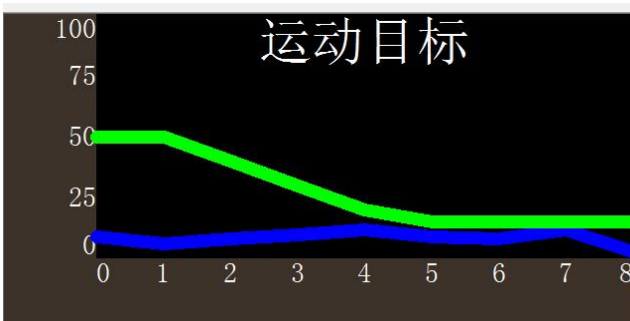

绿色线：设置的灵敏度

蓝色线：每个距离门上的运动目标能量值

红色线：每个距离门上的静止目标能量值

5.4 Installation method and sensing range

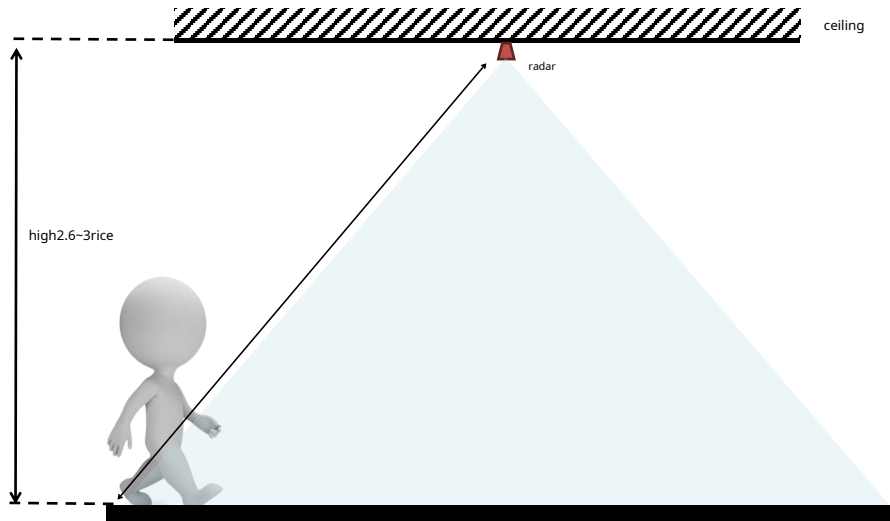
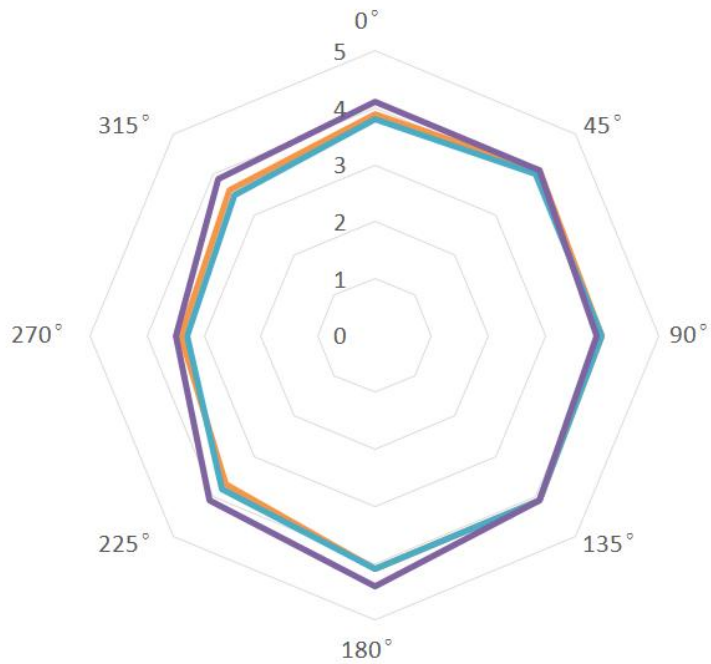
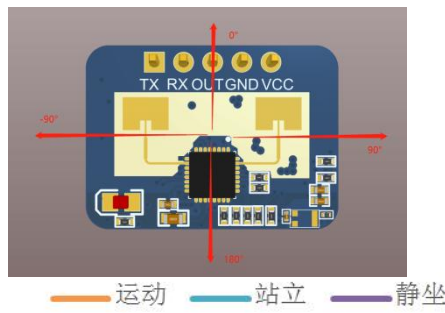
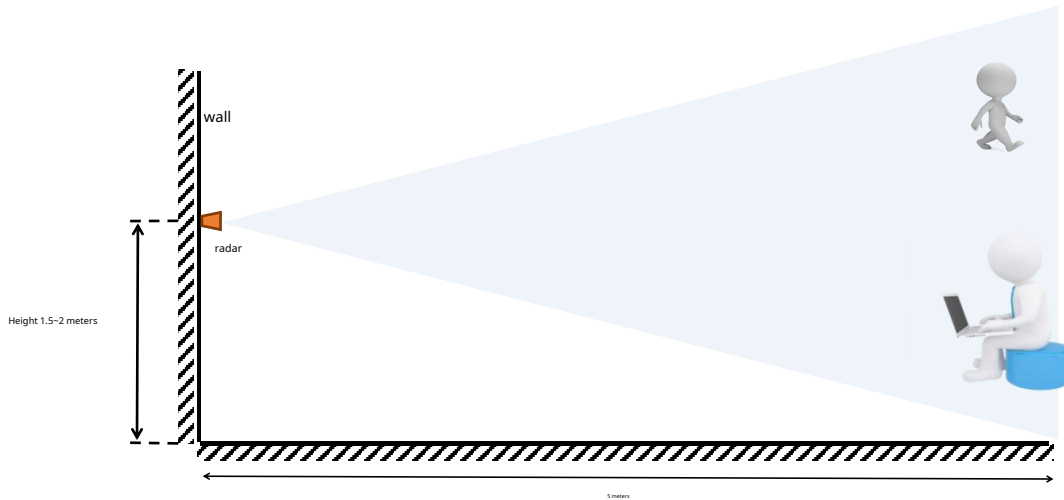

Figure 7 Schematic diagram of ceiling installation



(distance unit: meter, angle unit: degree)

Figure 8 Schematic diagram of the detection range (the height of the ceiling is 3 meters)



(distance unit: meter, angle unit: degree)

Figure 9 Schematic diagram of wall-mounted installation

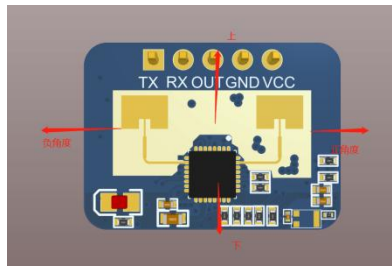

— 运动/m — 站立/m — 静坐/m

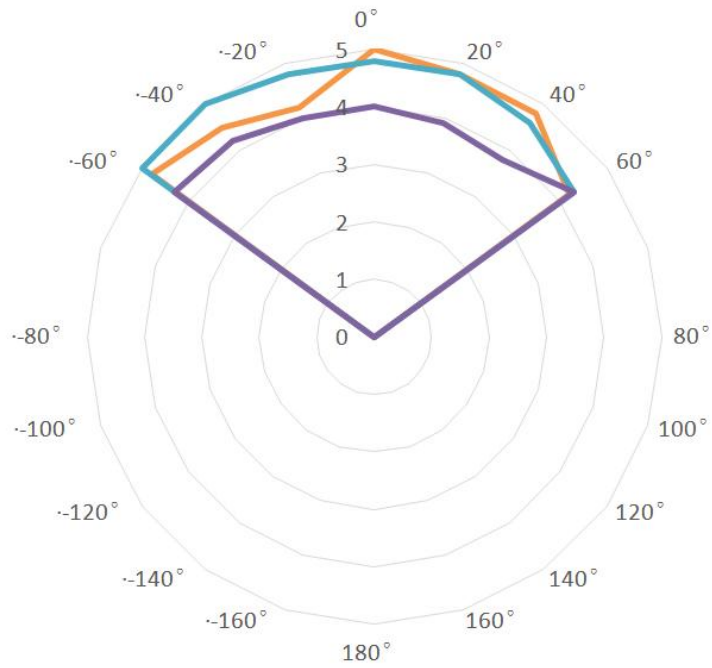

Figure 10 Schematic diagram of detection range (wall hanging height 1.5 meters)

5.5 Installation conditions

Confirm the minimum installation clearance

If the radar needs to be installed with a casing, the casing must have good wave-transmitting characteristics at 24GHz, and must not contain metal materials or materials that have a shielding effect on electromagnetic waves.

Installation environment requirements

This product needs to be installed in a suitable environment. If it is used in the following environments, the detection effect will be affected:

- There are continuously moving non-human objects in the sensing area, such as animals, continuously swinging curtains, large green plants facing the air outlet, etc.
- There is a large area of strong reflector in the sensing area, and the strong reflector will cause interference to the radar antenna
- When installing on the wall, it is necessary to consider external interference factors such as air conditioners and electric fans on the top of the room

Precautions during installation

- Try to ensure that the radar antenna is facing the area to be detected, and the surrounding area of the antenna is open and unobstructed
- To ensure that the installation position of the sensor is firm and stable, the shaking of the radar itself will affect the detection effect
- Make sure there is no movement or vibration behind the radar. Due to the penetrating nature of radar waves, the antenna signal backlobe may detect moving objects behind the radar. Metal shields or metal backplanes can be used to shield the radar back lobe and reduce the impact of objects on the back of the radar
- The theoretical range accuracy of the radar is the result obtained through special algorithm processing on the basis of a physical resolution of 0.75 meters. Due to the difference in target size, state, RCS, etc., the target distance accuracy will fluctuate; at the same time, the farthest distance will also be slightly different. fluctuation

6 Bluetooth Instructions

6.1 Install the software

Currently the APP supports Android and IOS platforms, you can download it from this link: <https://www.pgyer.com/Lq8p> (Android)

You can also go to major app stores to search for "HLKRadarTools" and install it.



app icon

6.2 How to use

Open the app, and the app searches for nearby radar devices. The broadcast name of the device is "HLK-LD2410B_ xxxx" (xxxx is the last four digits of the mac address). After the module is successfully connected, you can view the radar information, or debug and save the parameters.

The distance of the APP should not exceed the signal range of Bluetooth (within 4 meters).

The screenshot displays the app's main interface for device management and parameter configuration. It includes a device list on the left, a central parameter configuration screen for a selected device (HLK-LD2410_A063), and a radar data visualization section with three graphs and a parameter table.

距离门	运动灵敏度	静止灵敏度	操作
距离门 0	50	0	设置
距离门 1	50	0	设置
距离门 2	40	40	设置
距离门 3	30	40	设置
距离门 4	20	30	设置
距离门 5	15	30	设置
距离门 6	15	20	设置
距离门 7	15	20	设置

① Search Bluetooth

② View parameters

③ Modify radar parameters

The process of modifying the radar parameters by the Bluetooth APP is consistent with that of the PC host computer tool.

6.3 Bluetooth password

You must enter a password to control the APP for the first connection. The default password is HiLink, which can be modified in Parameter Settings -> Control Password. The password is fixed at 6 bytes.



Note: Only V1.07.22091516 or newer version supports password function

6.4 OTA upgrade

When the firmware of the device has been updated, the word "upgradeable" will appear on the firmware version, long press the version number to enter the upgrade interface; only V1.07.22091516 or newer versions are supported for upgrades.



Long press the red circle to enter the upgrade

Enter OTA upgrade



The overall upgrade time takes 1~3 minutes. Must be in distance module within 3 meters Upgrade, otherwise the Bluetooth signal is poor and the upgrade will fail.

Do not power off or restart the module before the upgrade is completed, and do not forcibly exit the APP, otherwise the upgrade will fail. If the upgrade fails, the 2410CRadar program will fail, radar detection is not possible.

If the device upgrade fails, please restart the device and reconnect the APP, and a "waiting for upgrade" prompt will appear on the device list:



Click the device to be upgraded to re-upgrade, and the radar function can be restored only after the upgrade is successful.

6.5 Bluetooth communication protocol

2410C acts as a slave side, only allowed to be connected by one master.

Characteristic UUID	Operating authority	function definition
0000fff1-0000-1000-8000-00805f9b34fb	Read/Notify	Module sends, APP receives
0000fff2-0000-1000-8000-00805f9b34fb	Write Without Response	APP sends, module receives

When the app and 2410C Bluetooth connection and password verification are successful, the module will start the transparent transmission of radar data. The data transmitted by Bluetooth is exactly the same as the serial port protocol, please refer to "LD2410C Serial Communication Protocol.pdf" document.

If the App is successfully connected, it will send a Bluetooth password to the module for verification. Only when the password is correct, the module will start to transparently transmit data. For details, see "LD2410C Serial Communication Protocol.pdf" Obtaining Bluetooth Permissions section of .

6.6 Turn on Bluetooth again

The bluetooth function of LD2410C is enabled by default, and can be "LD2410C Serial Communication Protocol.pdf" Turn off or turn on Bluetooth. If the Bluetooth has been turned off, or the serial port cannot be used, power off the module within 2~3 seconds and then power on the module for more than 5 times to turn on the Bluetooth again.

7 Performance and Electrical Parameters

Working frequency	24GHz~ 24.25GHz Comply with FCC, CE, non-committee certification standards
power requirements	DC 5V, power supply capacity >200mA
Average working current	79 mA
Modulation	FMCW
interface	One GPIO, IO level 3.3V a UART
target application	human presence sensing
Detection distance	0.75m~6m, adjustable
detection angle	±60°
distance resolution	0.75m
Sweep bandwidth	250MHz Comply with FCC, CE, non-committee certification standards
ambient temperature	- 40 ~ 85°C
Dimensions	16mm x 22mm

Table 2 Performance and Electrical Parameters Table

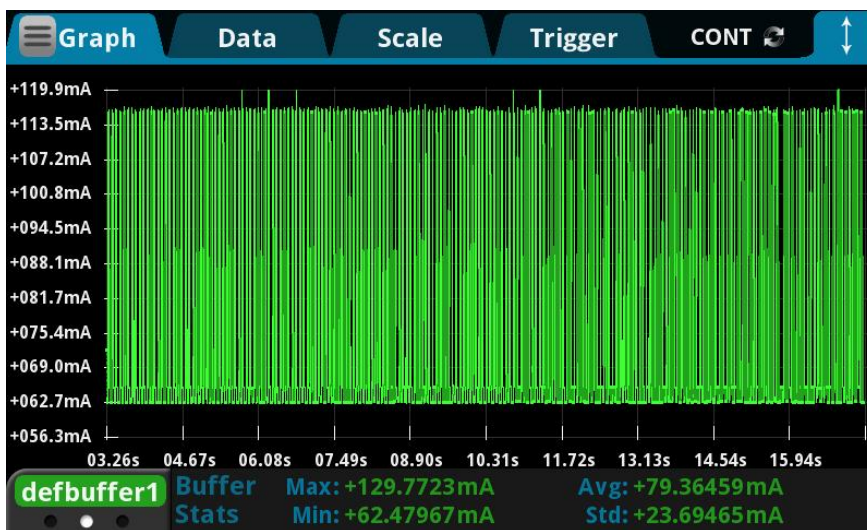
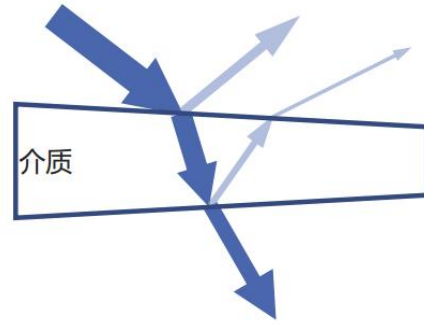

Figure 11 The measured data of the working current of the module

8 Radome Design Guidelines

8.1 Effect of Radome on the Performance of mmWave Sensors

- Radar waves are reflected on the radome boundary
- Loss of total power radiated or received by the radar
- The reflected wave enters the receiving channel, affecting the isolation between the transmitting and receiving channels
- Reflection may deteriorate the standing wave of the antenna, further affecting the antenna gain
- Radar waves will suffer loss when propagating in the medium. Theoretically, the higher the frequency, the greater the loss
- Electromagnetic waves are refracted to a certain extent when passing through a medium
- Affects the radiation pattern of the antenna and thus the coverage of the sensor



8.2 Design principles of radome

- 天线罩的结构形状
 - 表面光滑平整，厚度均匀一致。如平面或者球面，不能凹凸不平
 - 若有表面涂层，不能含有金属或导电的材料
 - 在天线正上方，天线罩面与天线平面保持平行
- 天线到天线罩内表面的高度H
 - 理想的高度是空气中电磁波半波长的整数倍
 - $H = \frac{m}{2} * \frac{c_0}{f}$ ，其中m为正整数， c_0 为真空光速， f 为工作中心频率
 - 比如，24.125GHz中心频率，其在空气中的半波长约6.2mm
- 天线罩的厚度D
 - 理想的厚度是介质中电磁波半波长的整数倍
 - $D = \frac{m}{2} * \frac{c_0}{f\sqrt{\epsilon_r}}$ ，其中m为正整数， ϵ_r 为天线罩材质的相对介电常数
 - 比如某ABS材料 $\epsilon_r = 2.5$ ，其半波长约3.92mm

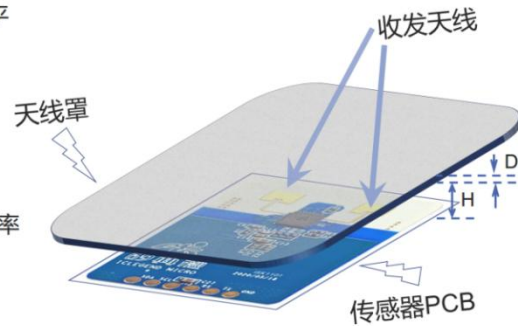

8.3 common material

- Before designing, understand the material and electrical characteristics of the radome
 - The table on the right is for reference only, please confirm with the supplier for the actual value
- Height H from the antenna to the inner surface of the radome
 - When space permits, 1x or 1.5x wavelength is preferred
 - For example, 12.4 or 18.6mm is recommended for 24.125GHz
 - Error control: $\pm 1.2\text{mm}$
- Thickness D of the radome
 - Recommended half-wavelength, error control $\pm 20\%$
 - If the half-wavelength thickness requirement cannot be met
 - It is recommended to use low ϵ_r material
 - Recommended thickness is 1/8 wavelength or thinner

常见材料特性 (基于24.125GHz)

介质	ϵ_r 典型值	半波长 (mm)	1/8波长 (mm)	1/10波长 (mm)
空气	1.00	6.20	1.55	1.24
ABS1	1.50	5.06	1.27	1.01
ABS2	2.50	3.92	0.98	0.78
PC材料	3.00	3.58	0.89	0.72
PMMA亚克力1	2.00	4.38	1.10	0.88
PMMA亚克力2	5.00	2.77	0.69	0.55
PVC硬	4.00	3.10	0.78	0.62
PVC软	8.00	2.19	0.55	0.44
高密度PE	2.40	4.00	1.00	0.80
低密度PE	2.30	4.09	1.02	0.82
石英玻璃	5	2.77	0.69	0.55

Table 3 Common material properties of radome

- The influence of inhomogeneous materials or multi-layer composite materials on radar performance, it is recommended to make experimental adjustments during design

9 Revision History

date	Version	Modify content
2022-11-7	1.00	initial version

10 Technical support and contact information



Shenzhen Hailingke Electronics Co., Ltd.

Tel: 0755-23152658/83575155

Website: www.hlktech.com

